



Wireless Components

2 Band TV Tuner Mixer-Oscillator-PLL with balanced IF-Amplifier
TUA6024 Version 2.0

Specification December 1999

Revision History: Current Version: 12.99		
Previous Version: Target Data Sheet		
Page (in previous Version)	Page (in current Version)	Subjects (major changes since last revision)
div	div	new layout

ABM®, AOP®, ARCOFI®, ARCOFI®-BA, ARCOFI®-SP, DigiTape®, EPIC®-1, EPIC®-S, ELIC®, FALC®54, FALC®56, FALC®-E1, FALC®-LH, IDEC®, IOM®, IOM®-1, IOM®-2, IPAT®-2, ISAC®-P, ISAC®-S, ISAC®-S TE, ISAC®-P TE, ITAC®, IWE®, MUSAC®-A, OCTAT®-P, QUAT®-S, SICAT®, SICOFI®, SICOFI®-2, SICOFI®-4, SICOFI®-4µC, SLICOFI® are registered trademarks of Infineon Technologies AG.

ACE™, ASM™, ASP™, POTSWIRE™, QuadFALC™, SCOUT™ are trademarks of Infineon Technologies AG.

Edition 03.99

**Published by Infineon Technologies AG i. Gr.,
SC,
Balanstraße 73,
81541 München**

© Infineon Technologies AG i. Gr. 13.01.00.
All Rights Reserved.

Attention please!

As far as patents or other rights of third parties are concerned, liability is only assumed for components, not for applications, processes and circuits implemented within components or assemblies.

The information describes the type of component and shall not be considered as assured characteristics.

Terms of delivery and rights to change design reserved.

Due to technical requirements components may contain dangerous substances. For information on the types in question please contact your nearest Infineon Technologies Office.

Infineon Technologies AG is an approved CECC manufacturer.

Packing

Please use the recycling operators known to you. We can also help you – get in touch with your nearest sales office. By agreement we will take packing material back, if it is sorted. You must bear the costs of transport.

For packing material that is returned to us unsorted or which we are not obliged to accept, we shall have to invoice you for any costs incurred.

Components used in life-support devices or systems must be expressly authorized for such purpose!

Critical components¹ of the Infineon Technologies AG, may only be used in life-support devices or systems² with the express written approval of the Infineon Technologies AG.

1 A critical component is a component used in a life-support device or system whose failure can reasonably be expected to cause the failure of that life-support device or system, or to affect its safety or effectiveness of that device or system.

2 Life support devices or systems are intended (a) to be implanted in the human body, or (b) to support and/or maintain and sustain human life. If they fail, it is reasonable to assume that the health of the user may be endangered.

Product Info

General Description The **TUA6024** is a 5 V mixer/oscillator and sythesizer for analog and digital TV and VCR tuners.

Package

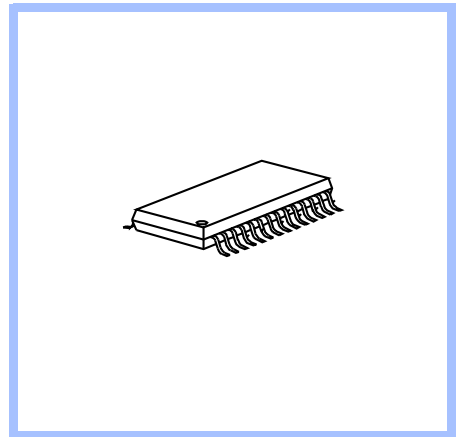

Features

General

- Suitable for analog and digital terrestrial TV tuner
- Full ESD protection

Mixer/Oscillator

- High impedance mixer input for LOW/MID band
- Low impedance mixer input for HIGH band
- 4 pin oscillator for LOW/MID band
- 4 pin oscillator for HIGH band

IF-Amplifier

- balanced SAW preamplifier
- Low output impedance

PLL

- PLL with short lock-in time
- High voltage VCO tuning output

- Fast I²C bus
- 3 NPN bandswitch buffers
- Internal LOW-MID/HIGH switch
- Lock-in flag
- Power-down reset
- Programmable reference divider ratios: 64, 80, 128
- Programmable charge pump current

Application

- The IC is suitable for PAL tuner in TV- and VCR-sets or set-top receivers for analog TV and Digital Video Broadcasting.

Ordering Information

Type	Ordering Code	Package
TUA6024-K	Q67037-A1057	P-TSSOP-28-1
TUA6024-S	Q67037-A1056	P-TSSOP-28-1

1

Table of Contents

1	Table of Contents	1-1
2	Product Description	2-1
2.1	General Description	2-2
2.2	Features	2-2
2.3	Application	2-3
2.4	Package Outlines	2-3
3	Functional Description	3-1
3.1	Pin Configuration	3-2
3.2	Internal Pin Configuration	3-3
3.3	Block Diagram	3-7
3.4	Circuit Description	3-8
4	Applications	4-1
4.1	Circuit	4-2
5	Reference	5-1
5.1	Electrical Data	5-2
5.1.1	Absolute Maximum Ratings	5-2
5.1.2	Operating Range	5-4
5.1.3	AC/DC Characteristics	5-5
5.2	Programming	5-10
	Table 5-4 Bit Allocation Read / Write	5-10
	Table 5-5 Description of symbols	5-10
	Table 5-6 Address selection	5-11
	Table 5-7 Test modes	5-11
	Table 5-8 Reference divider ratio	5-11
5.3	I2C Bus Timing Diagram	5-12
5.4	Test Circuits	5-13
5.4.1	Gain (GV) test Set-up in LOW/MID	5-13
5.4.2	Gain (GV) test Set-up in HIGH	5-13
5.4.3	Matching circuit for optimum noise figure in LOW/MID	5-14
5.4.4	Noise Figure Test Set-up in LOW/MID	5-14
5.4.5	Noise Figure Test Set-up in HIGH	5-15
5.4.6	Measurement of fref and fdiv	5-15

2 Product Description

Contents of this Chapter

2.1	General Description	2-2
2.2	Features	2-2
2.3	Application	2-3
2.4	Package Outlines	2-3

2.1 General Description

The **TUA6024** device combines a digitally programmable phase locked loop (PLL), with a mixer-oscillator block including two balanced mixers and oscillators for use in TV and VCR tuners.

The PLL block with four selectable chip addresses forms a digitally programmable phase locked loop. With a 4 MHz quartz crystal, the PLL permits precise setting of the frequency of the tuner oscillator up to 900 MHz in increments of 31.25, 50 or 62.5 kHz. The tuning process is controlled by a microprocessor via an I²C bus. The device has three output ports. A flag is set when the loop is locked it can be read by the processor via the I²C bus.

The mixer-oscillator block includes two balanced mixers (one mixer with high-impedance input and one mixer with a balanced low-impedance input), two frequency and amplitude-stable balanced oscillators for LOW/MID and HIGH, an IF amplifier, a low-noise reference voltage source, and a band switch.

2.2 Features

General

- Suitable for analog and digital terrestrial TV tuner
- Full ESD protection

Mixer/Oscillator

- High impedance mixer input for LOW/MID band
- Low impedance mixer input for HIGH band
- 4 pin oscillator for LOW/MID band
- 4 pin oscillator for HIGH band

IF-Amplifier

- balanced SAW preamplifier
- Low output impedance

PLL

- PLL with short lock-in time
- High voltage VCO tuning output
- Fast I²C bus
- 3 NPN bandswitch buffers
- Internal LOW-MID/HIGH switch
- Lock-in flag
- Power-down reset

- Programmable reference divider ratios: 64, 80, 128
- Programmable charge pump current

2.3 Application

- The IC is suitable for PAL tuners in TV- and VCR-sets or set-top receivers for analog TV and Digital Video Broadcasting.

2.4 Package Outlines

P-TSSOP-28-1

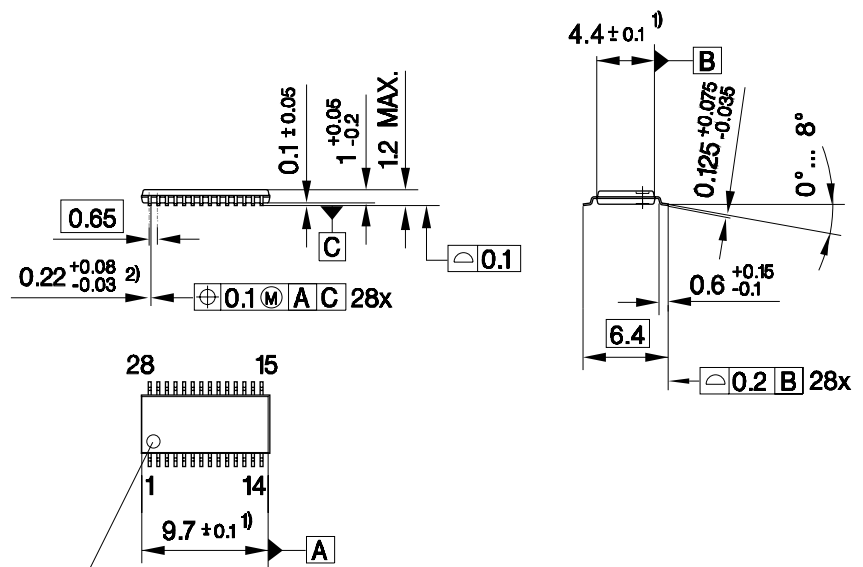

Index Marking

- 1) Does not include plastic or metal protrusion of 0.15 max. per side
- 2) Does not include dambar protrusion

3 Functional Description

Contents of this Chapter

3.1	Pin Configuration	3-2
3.2	Internal Pin Configuration	3-3
3.3	Block Diagram	3-7
3.4	Circuit Description	3-8
3.4.1	Mixer-Oscillator block	3-8
3.4.2	PLL block	3-8
3.4.3	I2C-Bus Interface	3-9

3.1 Pin Configuration

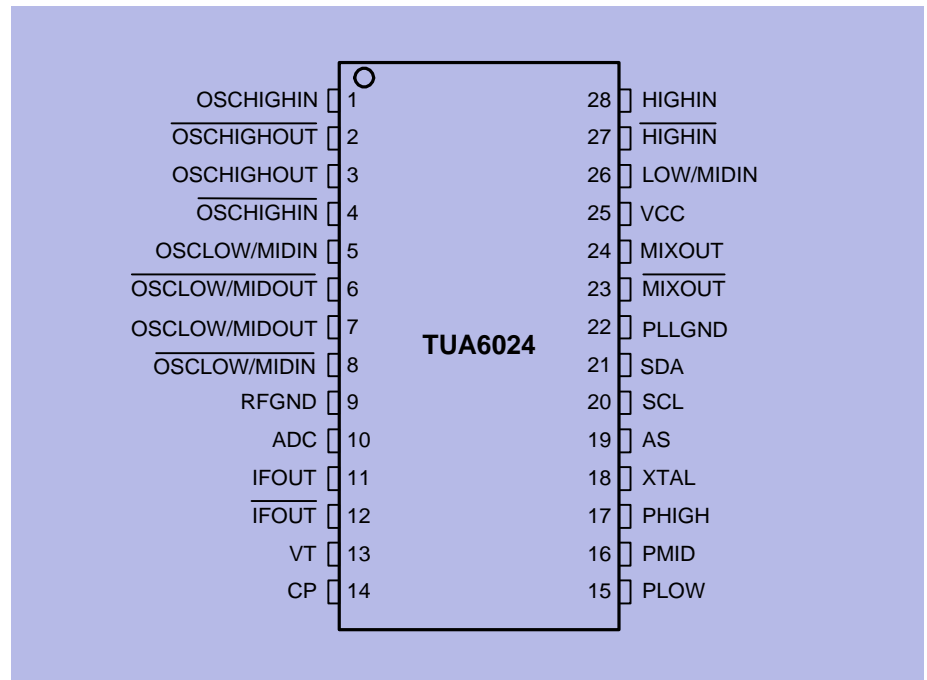

Pin_config

Figure 3-1 Pin Configuration

3.2 Internal Pin Configuration

Table 3-1 Pin Definition and Function

Pin No.	Symbol	Equivalent I/O-Schematic	Average DC voltage	
			LOW/MID	HIGH
1	OSCHIGHIN	 <p>The schematic shows a differential pair of transistors with a common emitter resistor. The bases are connected to pins 2 and 3. The emitters are connected to pins 1 and 4. There are pull-up resistors on pins 2 and 3, and pull-down resistors on pins 1 and 4. The common emitter is connected to ground through a resistor.</p>	0.0 V	1.6 V
2	OSC-HIGHOUT		0.0 V	2.3 V
3	OSC-HIGHOUT		0.0 V	2.3 V
4	OSCHIGHIN		0.0 V	1.6 V
5	OSCLOW/MIDIN	 <p>The schematic shows a differential pair of transistors with a common emitter resistor. The bases are connected to pins 6 and 7. The emitters are connected to pins 5 and 8. There are pull-up resistors on pins 6 and 7, and pull-down resistors on pins 5 and 8. The common emitter is connected to ground through a resistor.</p>	1.6 V	0.0 V
6	OSCLOW/MIDOUT		2.8 V	0.0 V
7	OSCLOW/MIDOUT		2.8 V	0.0 V
8	OSCLOW/MIDIN		1.6 V	0.0 V

Table 3-1 Pin Definition and Function (continued)

Pin No.	Symbol	Equivalent I/O-Schematic	Average DC voltage	
			LOW/MID	HIGH
9	RFGND	analog ground	0.0 V	0.0 V
10	ADC		V_{ADC}	V_{ADC}
11	IFOUT		2.3 V	2.3 V
12	\overline{IFOUT}		2.3 V	2.3 V
13	VT		V_T	V_T
14	CP		1.9 V	1.9 V

Table 3-1 Pin Definition and Function (continued)

Pin No.	Symbol	Equivalent I/O-Schematic	Average DC voltage	
			LOW/MID	HIGH
15	PMID		5 V or V_{CE}	5 V
16	PLOW		5 V or V_{CE}	5 V
17	PHIGH		5 V	V_{CE}
18	XTAL		3.0 V	3.0 V
19	AS		V_{AS}	V_{AS}
20	SCL		n.a.	n.a.

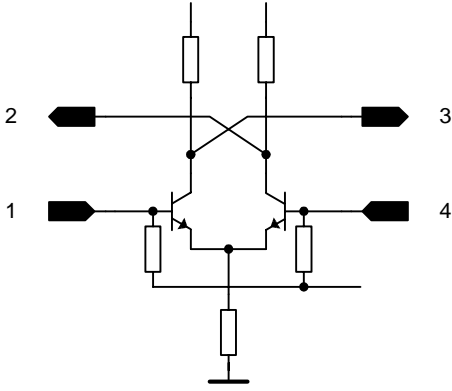
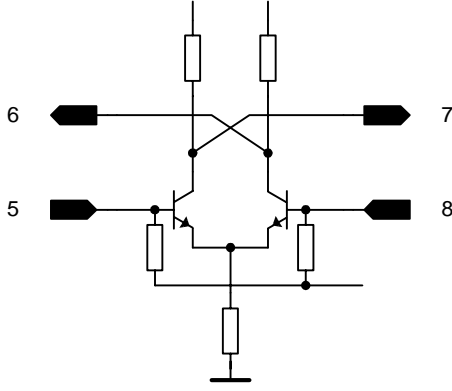
Table 3-1 Pin Definition and Function (continued)

Pin No.	Symbol	Equivalent I/O-Schematic	Average DC voltage	
			LOW/MID	HIGH
21	SDA		n.a.	n.a.
22	PLLGND	digital ground	0.0 V	0.0 V
23	MIXOUT		3.8 V	3.8 V
24	MIXOUT		3.8 V	3.8 V
25	VCC	supply voltage	5.0 V	5.0 V
26	LOW/MIDIN		1.8 V	0.0 V
27	HIGHIN		0.0 V	0.9 V
28	HIGHIN		0.0 V	0.9 V

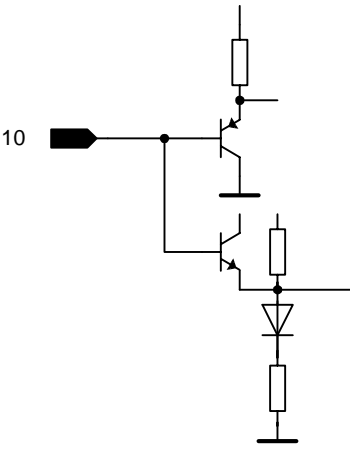
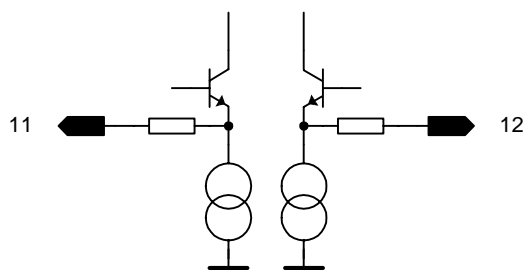
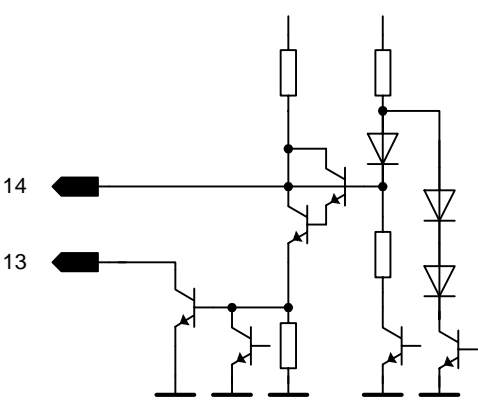
3.3 Block Diagram

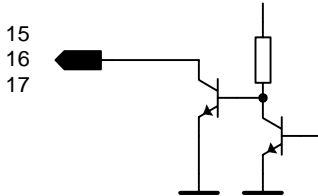
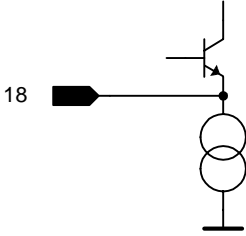
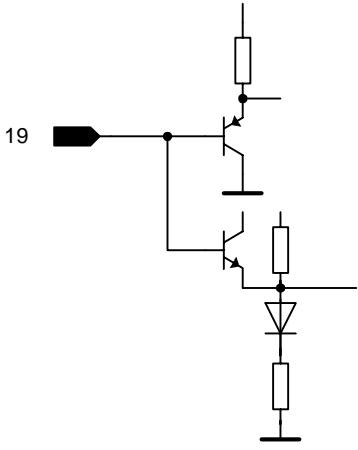
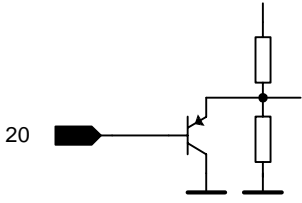
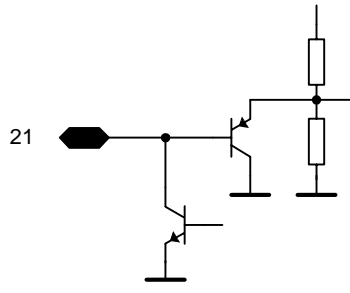
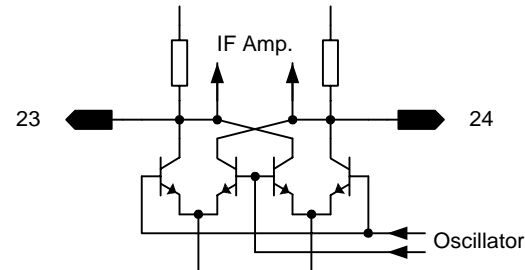
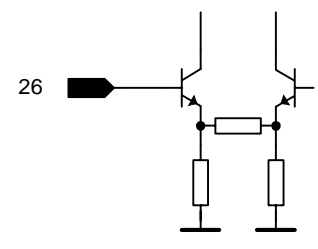
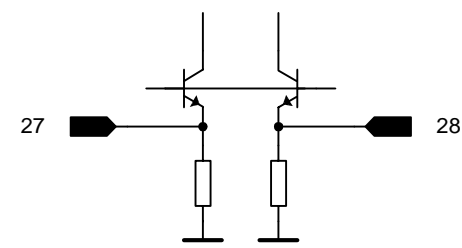
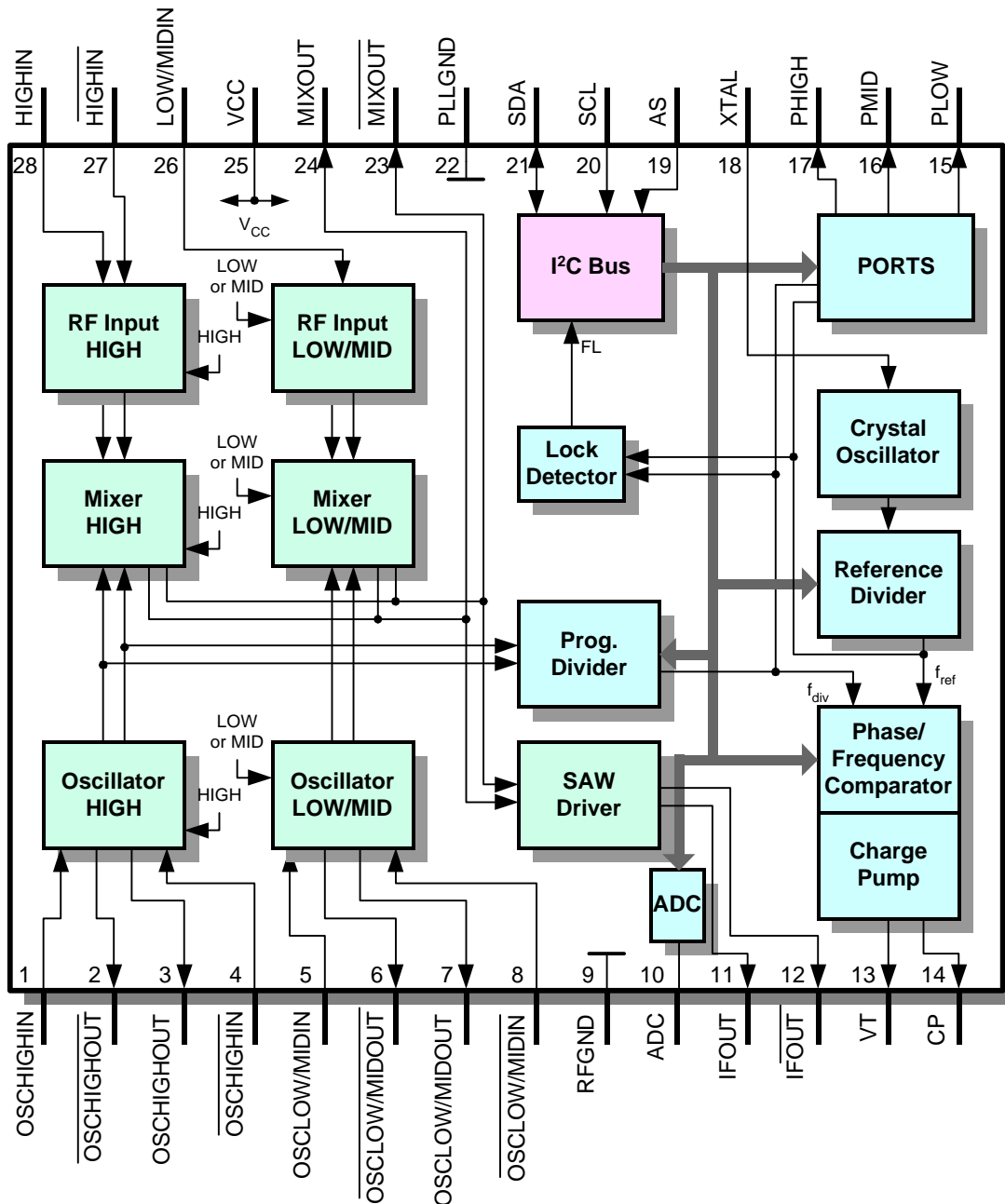

Block_diag

Figure 3-2 Block Diagram

3.4 Circuit Description

3.4.1 Mixer-Oscillator block

The mixer oscillator section includes two balanced mixers (double balanced mixer), two balanced oscillators for LOW and / or MID band and HIGH, a reference voltage source and a band switch.

Filters between tuner input and IC separate the TV frequency signals into two bands. The band switching in the tuner front-end is done by using two or three port outputs. In the selected band the signal passes a tuner input stage with MOSFET amplifier, a double-tuned bandpass filter and is then fed to the balanced mixer input of the IC which has in case of LOW / MID a high-impedance input and in case of HIGH a low-impedance input. The input signal is mixed there with the signal from the activated on chip oscillator to the IF frequency which is filtered out at the balanced high-impedance output pair by means of a parallel tuned circuit. The following SAW preamplifier has a low output impedance to drive the SAW filter directly.

3.4.2 PLL block

The oscillator signal is internally DC-coupled as a differential signal to the programmable divider inputs. The signal subsequently passes through a programmable divider with ratio $N = 256$ through 32767 and is then compared in a digital frequency / phase detector to a reference frequency $f_{ref} = 31.25, 50$ or 62.5 kHz.

This frequency is derived from a unbalanced, low-impedance 4 MHz crystal oscillator (pin XTAL) divided by $R = 128, 80$ or 64 .

The phase detector has two outputs that drive two current sources of opposite polarity as charge pump. If the negative edge of the divided VCO signal appears prior to the negative edge of the reference signal, the positive current source pulses for the duration of the phase difference. In the reverse case the I- current source pulses. If the two signals are in phase, the charge pump output (CP) goes into the high-impedance state (PLL is locked). An active low-pass filter integrates the current pulses to generate the tuning voltage for the VCO (internal amplifier, external pullup resistor at TUNE and external RC circuitry). The charge pump output is also switched into the high-impedance state if the control bit $T0 = 1$. Here it should be noted, however, that the tuning voltage can alter over a long period in the high-impedance state as a result of self-discharge in the peripheral circuitry. TUNE may be switched off by the control bit OS to allow external adjustments.

If the VCO is not oscillating the PLL locks to a tuning voltage of 33V .

By means of control bit CP the pump current can be switched between two values by software. This programmability permits alteration of the control response of the PLL in the locked-in state. In this way different VCO gains can be compensated, for example.

The software-switched ports PLOW, PMID and PHIGH are general-purpose open-collector outputs. The test bit T1 = 1, switches the test signals f_{ref} (i.e. $f_{XTAL} / 64$) and f_{div} (divided input signal) to PLOW and PMID respectively.

The lock detector resets the lock flag FL if the width of the charge pump current pulses is wider than the period of the crystal oscillator (i.e. 250 ns). Hence, if FL = 1, the maximum deviation of the input frequency from the programmed frequency is given by

$$\Delta f = \pm I_P (K_{VCO} / f_{XTAL}) (C1+C2) / (C1C2)$$

where I_P is the charge pump current, K_{VCO} the VCO gain, f_{XTAL} the crystal oscillator frequency and C1, C2 the capacitances in the loop filter (see [Figure 4-1 Evaluation Board on page 2](#)). As the charge pump pulses at i.e. 62.5 kHz (= f_{ref}), it takes a maximum of 16 μ s for FL to be reset after the loop has lost lock state.

Once FL has been reset, it is set only if the charge pump pulse width is less than 250 ns for eight consecutive f_{ref} periods. Therefore it takes between 128 and 144 μ s for FL to be set after the loop regains lock.

3.4.3 I²C-Bus Interface

Data is exchanged between the processor and the PLL via the I²C bus. The clock is generated by the processor (input SCL), while pin SDA functions as an input or output depending on the direction of the data (open collector, external pull-up resistor). Both inputs have hysteresis and a low-pass characteristic, which enhance the noise immunity of the I²C bus.

The data from the processor pass through an I²C bus controller. Depending on their function the data are subsequently stored in registers. If the bus is free, both lines will be in the marking state (SDA, SCL are HIGH). Each telegram begins with the start condition and ends with the stop condition. Start condition: SDA goes LOW, while SCL remains HIGH. Stop condition: SDA goes HIGH while SCL remains HIGH. All further information transfer takes place during SCL = LOW, and the data is forwarded to the control logic on the positive clock edge.

The table "Bit Allocation" (see [Table 5-4 Bit Allocation Read / Write on page 10](#)) should be referred to the following description. All telegrams are transmitted byte-by-byte, followed by a ninth clock pulse, during which the control logic returns the SDA line to LOW (acknowledge condition). The first byte is comprised of seven address bits. These are used by the processor to select the PLL from several peripheral components (chip select). The LSB bit (R/W) determines whether data are written into (R/W = 0) or read from (R/W = 1) the PLL.

In the data portion of the telegram during a WRITE operation, the MSB bit of the first or third data byte determines whether a divider ratio or control information is to follow. In each case the second byte of the same data type has to follow the first byte.

If the address byte indicates a READ operation, the PLL generates an acknowledge and then shifts out the status byte onto the SDA line. If the processor generates an acknowledge, a further status byte is output; otherwise the data line is released to allow the processor to generate a stop condition. The status word consists the lock flag and the power-on flag.

Four different chip addresses can be set by appropriate DC level at pin AS (see [Table 5-6 Address selection on page 11](#)).

While applying the supply voltage, a power-on reset circuit prevents the PLL from setting the SDA line to LOW, which would block the bus. The power-on reset flag POR is set at power-on and when V_{CC} falls below 3.2 V. It will be reset at the end of a READ operation.

4 Applications

Contents of this Chapter

4.1	Circuit	4-2
-----	---------------	-----

4.1 Circuit

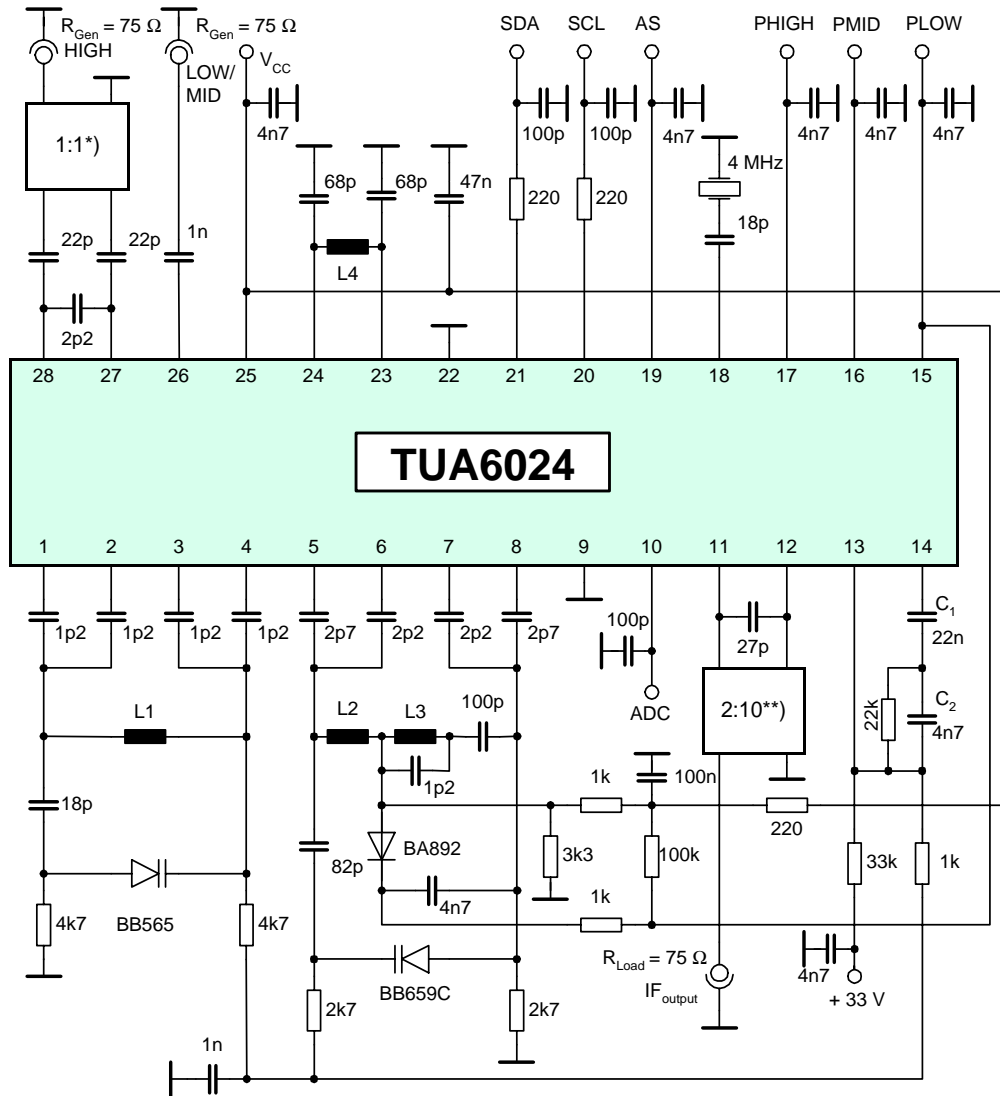

Application Circuit.wmf

Figure 4-1 Evaluation Board

	Table 4-1 Recommended band limits in MHz			
	RF input		Oscillator	
	min	max	min	max
LOW	48.25	147.25	87.15	186.15
MID	154.25	423.25	193.15	462.25
HIGH	432.25	855.25	471.25	894.25

	Table 4-1 Coils		
	turns	∅	wire ∅
L1	1.5	2 mm	0.4 mm
L2	3.5	2.5 mm	0.5 mm
L3	8.5	3 mm	0.5 mm
L4	14.5	4 mm	0.3 mm
*)	TOKO B4F Type 617DB-1023		
**)	TOKO 7KL600 GCS-A1010DX		

5 Reference

Contents of this Chapter

5.1 Electrical Data	5-2
5.1.1 Absolute Maximum Ratings	5-2
5.1.2 Operating Range	5-4
5.1.3 AC/DC Characteristics	5-5
5.2 Programming	5-10
Table 5-4 Bit Allocation Read / Write	5-10
Table 5-5 Description of symbols	5-10
Table 5-6 Address selection	5-11
Table 5-7 Test modes	5-11
Table 5-8 Reference divider ratio	5-11
Table 5-9 A/D converter levels	5-11
5.3 I2C Bus Timing Diagram	5-12
5.4 Test Circuits	5-13
5.4.1 Gain (GV) test Set-up in LOW/MID	5-13
5.4.2 Gain (GV) test Set-up in HIGH	5-13
5.4.3 Matching circuit for optimum noise figure in LOW/MID	5-14
5.4.4 Noise Figure Test Set-up in LOW/MID	5-14
5.4.5 Noise Figure Test Set-up in HIGH	5-15
5.4.6 Measurement of f_{ref} and f_{div}	5-15

5.1 Electrical Data

5.1.1 Absolute Maximum Ratings



WARNING

The maximum ratings may not be exceeded under any circumstances, not even momentarily and individually, as permanent damage to the IC may result.

Table 5-1 Absolute Maximum Ratings, Ambient temperature $T_{AMB} = -20^{\circ}\text{C} \dots +85^{\circ}\text{C}$

Parameter ¹⁾	Symbol	Limit Values		Unit	Remarks
		min	max		
Supply voltage	V_{CC}	-0.3	6	V	
Junction temperature	T_J		+150	$^{\circ}\text{C}$	
Storage temperature	T_{Stg}	-40	+125	$^{\circ}\text{C}$	
Thermal resistance (junction to ambient)	R_{thJA}		120	K/W	
PLL					
CP	V_{CHGPMP}	-0.3	3	V	
	I_{CHGPMP}		1	mA	
Crystal oscillator pin XTAL	V_{XTAL}		V_{CC}	V	
	I_{XTAL}	-5		mA	
Bus input/output SDA	V_{SDA}	-0.3	V_{CC}	V	
Bus output current SDA	$I_{SDA(L)}$		5	mA	open collector
Bus input SCL	V_{SCL}	-0.3	V_{CC}	V	
Chip address switch AS	V_{AS}	-0.3	V_{CC}	V	
VCO tuning output (loop filter)	V_T	-0.3	35	V	
Port outputs PLOW, PMID, PHIGH	V_P	-0.3	V_{CC}	V	
	$I_{P(L)}$	-1	25	mA	$t_{max} = 0.1 \text{ sec. at } 5.5 \text{ V}$
Total port output current	$\Sigma I_{P(L)}$		40	mA	$t_{max} = 0.1 \text{ sec. at } 5.5 \text{ V}$
Mixer-Oscillator					
Mix inputs LOW/MID	$V_{MIX V}$	-0.3	3	V	
Mix inputs HIGH	$V_{MIX U}$		2	V	
	$I_{MIX U}$	-5	6	mA	

Table 5-1 Absolute Maximum Ratings, Ambient temperature $T_{AMB} = -20^{\circ}\text{C} \dots + 85^{\circ}\text{C}$ (continued)

Parameter ¹⁾	Symbol	Limit Values		Unit	Remarks
		min	max		
VCO base voltage	V_B	-0.3	3	V	
VCO collector voltage	V_C		V_{CC}	V	
ESD-Protection ²⁾					
all pins	V_{ESD}		1	kV	

- 1). All values are referred to ground (pin), unless stated otherwise.
Currents with a positive sign flows into the pin and currents with a negative sign flows out of pin.
- 2). According to MIL STD 883D, method 3015.7 and EOS/ESD assn. standard S5.1 - 1993

5.1.2 Operating Range

Within the operational range the IC operates as described in the circuit description. The AC / DC characteristic limits are not guaranteed.

Table 5-2 Operating Range

Parameter	Symbol	Limit Values		Unit	Test Conditions	L	Item
		min	max				
Supply voltage	V_{CC}	+4.5	+5.5	V			
Programmable divider factor	N	256	32767				
LOW/MID Mixer input frequency range	f_{MIXV}	30	500	MHz			
HIGH Mixer input frequency range	f_{MIXU}	400	900	MHz			
LOW/MID Oscillator frequency range	f_{OH}	65	560	MHz			
HIGH Oscillator frequency range	f_{OU}	430	950	MHz			
Ambient temperature	T_{amb}	-20	+85	°C			

5.1.3 AC/DC Characteristics

AC / DC characteristics involve the spread of values guaranteed in the specified supply voltage and ambient temperature range. Typical characteristics are the median of the production.

Table 5-3 AC/DC Characteristics with T_A 25 °C, V_{CC}

	Symbol	Limit Values			Unit	Test Conditions	L	Item
		min	typ	max				
Supply								
Supply voltage	V_{CC}	4.5	5	5.5	V			
Current consumption	I_{CC}	56	70	84	mA			
Digital Unit								
PLL								
Crystal oscillator connections XTAL								
Crystal frequency	f_{XTAL}	3.2	4.0	4.8	MHz	series resonance		
Crystal resistance	R_{XTAL}	10		100	Ω	series resonance		
Oscillation frequency	f_{XTAL}	3,99975	4,000	4,00025	MHz	$f_{XTAL} = 4$ MHz		
Input impedance	Z_{XTAL}	-500	-700	-900	Ω	$f_{XTAL} = 4$ MHz		
Charge pump output CP								
HIGH output current	I_{CPH}	± 90	± 220	± 300	μA	CP = 1, $V_{CP} = 2$ V		
LOW output current	I_{CPL}	± 22	± 50	± 75	μA	CP = 0, $V_{CP} = 2$ V		
Tristate current	I_{CPZ}		+1		nA	T0 = 1, $V_{CP} = 2$ V		
Output voltage	V_{CP}	1.0		2.5	V	PLL locked		
Drive output VT (open collector)								
HIGH output current	I_{TH}			10	μA	$V_{TH} = 33$ V, T0 = 1		
LOW output voltage	V_{TL}			0.4	V	$I_{TL} = 1.0$ mA		
I²C-Bus								
Bus inputs SCL, SDA								
HIGH input voltage	V_{IH}	3		5.5	V			
LOW input voltage	V_{IL}	0		1.5	V			
HIGH input current	I_{IH}			10	μA	$V_{IH} = V_S$		
LOW input current	I_{IL}	-10			μA	$V_{IL} = 0$ V		
Bus output SDA (open collector)								
HIGH output current	I_{OH}			10	μA	$V_{OH} = 5.5$ V		
LOW output voltage	V_{OL}			0.4	V	$I_{OL} = 3$ mA		

Table 5-3 AC/DC Characteristics with T_A 25 °C, V_{CC} (continued)

	Symbol	Limit Values			Unit	Test Conditions	L	Item
		min	typ	max				
Edge speed SCL,SDA								
Rise time	t_r			300	ns			
Fall time	t_f			300	ns			
Clock timing SCL								
Frequency	f_{SCL}	0		400	kHz			
HIGH pulse width	t_H	0.6			μ s			
LOW pulse width	t_L	1.3			μ s			
Start condition								
Set-up time	t_{susta}	0.6			μ s			
Hold time	t_{hsta}	0.6			μ s			
Stop condition								
Set up time	t_{susto}	0.6			μ s			
Bus free	t_{buf}	1.3			μ s			
Data transfer								
Set-up time	t_{sudat}	0.1			μ s			
Hold time	t_{hdat}	0			μ s			
Input hysteresis SCL, SDA	V_{hys}		200		mV			
Pulse width of spikes which are suppressed	t_{sp}	0		50	ns			
Capacitive load for each bus line	C_L			400	pF			
Port outputs PLOW, PMID, PHIGH (open collector)								
HIGH output current	I_{POH}			1	μ A	$V_{POH} = 5$ V		
LOW output voltage	V_{POL}			0.5	V	$I_{POL} = 25$ mA		
ADC port input								
HIGH input current	I_{ADCH}			10	μ A			
LOW input current	I_{ADCL}	-10			μ A			
Address selection input AS								
HIGH input current	I_{ASH}			50	μ A	$V_{ASH} = 5$ V		
LOW input current	I_{ASL}	-50			μ A	$V_{ASL} = 0$ V		

Table 5-3 AC/DC Characteristics with T_A 25 °C, V_{CC} (continued)

	Symbol	Limit Values			Unit	Test Conditions	L	Item
		min	typ	max				
Analog Unit								
LOW/MID Band Section (including IF amplifier)								
Voltage gain	G_V	20	23	26	dB	$f_{RF} = 43.25$ to 463.25 MHz, $f_{IF} = 33.4$ to 58.75 MHz		
Mixer noise figure	NF		9	11	dB	$f_{RF} = 43.25$ to 463.25 MHz		
Mixer input impedance	R_i	1	2	3	k Ω	serial equivalent circuit, $f_{MixV} = 100$ MHz		
	C_i		2	3	pF	serial equivalent circuit, $f_{MixV} = 100$ MHz		
Oscillator frequency shift, PLL unlocked	$\Delta f_{Osc(V)}$			400	kHz	$V_{CC} = 5 V \pm 10\%$		
Oscillator frequency drift, PLL unlocked	$\Delta f_{Osc(T)}$			500	kHz	$\Delta T = 25$ °C		
Oscillator frequency drift, PLL unlocked	$\Delta f_{Osc(t)}$			100	kHz	$t = 5$ s up to 15 min after switching on		

Table 5-3 AC/DC Characteristics with T_A 25 °C, V_{CC} (continued)

	Symbol	Limit Values			Unit	Test Conditions	L	Item
		min	typ	max				
Oscillator pulling, PLL unlocked	V_i	100	108		dB μ V	$\Delta f = 10$ kHz $f_{RF} = 48.25$ MHz		
	V_i	100	108		dB μ V	$\Delta f = 10$ kHz $f_{RF} = 399.25$ MHz		
N + 5 pulling, PLL unlocked	N+5	-50			dBc	$f_{RF} = 48.25$ MHz, $f_{RF1} = 83.25$ MHz, $P_{RF}=P_{RF1} = 80$ dB μ V		
	N+5	-50			dBc	$f_{RF} = 399.25$ MHz, $f_{RF1} = 439.25$ MHz, $P_{RF}=P_{RF1} = 80$ dB μ V		
Oscillator phase noise ¹⁾ .	Φ_{OSC}	-80	-86		dBc/Hz	$f_m = 10$ kHz		
IF suppression	a_{IF}	15	20		dB	$V_{MixB} = 80$ dB μ V		
HIGH Band Section (including IF amplifier)								
Voltage gain	G_{MixU}	31	34	37	dB	$f_{RF} = 367.25$ MHz to 863.25 MHz, $f_{IF} = 33.4$ MHz to 58.75 MHz		
Mixer noise figure	NF_{MixU}		6	9	dB	$f_{RF} = 367.25$ to 615.25 MHz		
			7	10	dB	$f_{RF} = 623.25$ to 863.25 MHz		
Mixer input impedance	R_i	14	20	26	Ω	serial equivalent cir- cuit, $f_{MixU} = 600$ MHz		
	L_i	6	10	14	nH	serial equivalent cir- cuit, $f_{MixU} = 600$ MHz		

Table 5-3 AC/DC Characteristics with T_A 25 °C, V_{CC} (continued)

	Symbol	Limit Values			Unit	Test Conditions	L	Item
		min	typ	max				
Oscillator frequency shift, PLL unlocked	$\Delta f_{Osc(V)}$			400	kHz	$V_{CC} = 5 V \pm 10\%$		
Oscillator frequency drift, PLL unlocked	$\Delta f_{Osc(T)}$			800	kHz	$\Delta T = 25 \text{ }^\circ\text{C}$		
Oscillator frequency drift, PLL unlocked	$\Delta f_{Osc(t)}$			100	kHz	t = 5 s up to 15 min after switching on		
Oscillator pulling, PLL unlocked	V_{MIXU}	100	108		dB μ V	$\Delta f = 10 \text{ kHz}$ $f_{RF} = 375.25 \text{ MHz}$		
		100	108		dB μ V	$\Delta f = 10 \text{ kHz}$ $f_{RF} = 847.25 \text{ MHz}$		
N + 5 pulling, PLL unlocked	V_{MIXU}	-50			dBc	$f_{RF} = 471.25 \text{ MHz}$, $f_{RF1} = 511.25 \text{ MHz}$, $P_{RF} = P_{RF1} = 80 \text{ dB}\mu\text{V}$		
	V_{MIXU}	-50			dBc	$f_{RF} = 847.25 \text{ MHz}$, $f_{RF1} = 887.25 \text{ MHz}$, $P_{RF} = P_{RF1} = 80 \text{ dB}\mu\text{V}$		
Oscillator phase noise ¹⁾		-80	-86		dBc/Hz	$f_m = 10 \text{ kHz}$		
IF suppression	a_{IF}	15	20		dB	$V_{MIXB} = 80 \text{ dB}\mu\text{V}$		
SAW preamplifier								
IF output impedance	R_{IF}			80	Ω	serial equivalent circuit, $f_{IF} = 38.9 \text{ MHz}$		
	L_{IF}		7		nH			
Rejection at the IF outputs								
Divider interference rejection ²⁾	a	70			dBc	$P_{RF} = 80 \text{ dB}\mu\text{V}$		
Channel S02 beat rejection ²⁾	a	66			dBc	$f_{RF} = 76.25 \text{ MHz}$ $P_{RF} = 80 \text{ dB}\mu\text{V}$		

■ This value is only guaranteed in lab.

1). Measured in evaluation board.

2). Channel S02 beat is the interfering product of f_{RF} , f_{IF} and f_{OSC} of channel S02, $f_{beat} = 37.35 \text{ MHz}$. The possible mechanisms are $f_{OSC} - 2 \times f_{IF}$ or $2 \times f_{RFpix} - f_{OSC}$. Measured in evaluation board.

5.2 Programming

Table 5-4 Bit Allocation Read / Write

Byte	MSB	bit6	bit5	bit4	bit3	bit2	bit1	LSB	Ack	Remarks
Write Data										
Address Byte	1	1	0	0	0	MA1	MA0	0	A	
Progr. Divider Byte 1	0	N14	N13	N12	N11	N10	N9	N8	A	
Progr. Divider Byte 2	N7	N6	N5	N4	N3	N2	N1	N0	A	
Control Byte	1	CP	T1	T0	FP	RSA	RSB	OS	A	
Bandswitch Byte	x	x	x	x	x	P-HIGH	PMID 1.)	PLOW 1.)	A	TUA 6024-K
Bandswitch Byte	x	x	x	x	P-HIGH	x	PMID 1.)	PLOW 1.)	A	TUA 6024-S
Read Data										
Address Byte	1	1	0	0	0	MA1	MA0	1	A	
Status Byte	POR	FL	x	x	x	x	x	x	A	

1). In a tuner PLOW and PMID are interchangeable. Both bits switch the IC into LOW/MID (VHF) mode.

Table 5-5 Description of symbols

Symbol	Description
MA0, MA1	Address selection bits (see Table 5-6 Address selection on page 11)
N14 to N0	programmable divider bits: $N = 2^{14} \times N14 + 2^{13} \times N13 + \dots + 2^3 \times N3 + 2^2 \times N2 + 2^1 \times N1 + N0$
CP	charge pump current: bit = 0: charge pump current = 50 μ A bit = 1: charge pump current = 220 μ A
T1, T0	test bits (see Table 5-7 Test modes on page 11)
FP	reserved for future purposes, actually ignored, default: 1
RSA, RSB	reference divider bits (see Table 5-8 Reference divider ratio on page 11)
OS	tuning amplifier control bit: bit = 0: enable V_T bit = 1: disable V_T
PLOW, PMID, PHIGH	NPN ports control bits: bit = 0: NPN open-collector output is inactive bit = 1: NPN open-collector output is active
FL	PLL lock flag bit = 1: loop is locked
POR	Power-on reset flag flag is set at power-on and reset at the end of READ operation
x	don't care

Table 5-6 Address selection

Voltage at AS	MA1	MA0
$(0...0.1) * V_{CC}$	0	0
open circuit	0	1
$(0.4...0.6) * V_{CC}$	1	0
$(0.9...1) * V_{CC}$	1	1

Table 5-7 Test modes

Test mode	T1	T0
Normal operation	0	0
Charge pump output, CP is in high-impedance state	0	1
PLOW = f_{div} output, PMID = f_{ref} output	1	0
not used	1	1

Table 5-8 Reference divider ratio

Reference divider ratio	f_{ref} 1).	RSA	RSB
80	50 kHz	x	0
128	31.25 kHz	0	1
64	62.5 kHz	1	1

1). With a 4 MHz quartz.

Table 5-9 A/D converter levels

Voltage at ADC	A2	A1	A0
$(0...0.15)*V_{CC}$	0	0	0
$(0.15...0.3)*V_{CC}$	0	0	1
$(0.3...0.45)*V_{CC}$	0	1	0
$(0.45...0.6)*V_{CC}$	0	1	1
$(0.6...1)*V_{CC}$	1	0	0

5.3 I²C Bus Timing Diagram

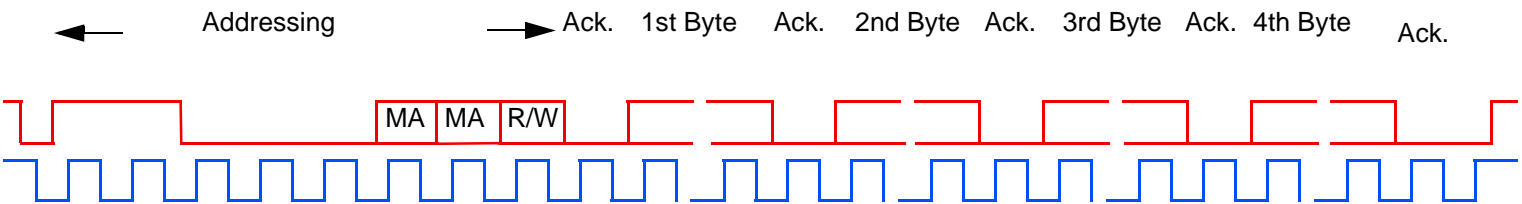

Note: SDA: — SCL: —

Telegram examples:

- Start-ADB-DB1-DB2-CB-BB-Stop
- Start-ADB-CB-BB-DB1-DB2-Stop
- Start-ADB-CB-AB-DB1-DB2-Stop
- Start-ADB-DB1-DB2-Stop
- Start-ADB-CB-BB-Stop

Abbreviations:

- Start= start condition
- ADB= address byte
- DB1= prog. divider byte 1
- DB2= prog. divider byte 2
- CB= Control byte
- BB= Bandswitch byte
- Stop= stop condition

5.4 Test Circuits

5.4.1 Gain (G_V) test Set-up in LOW/MID

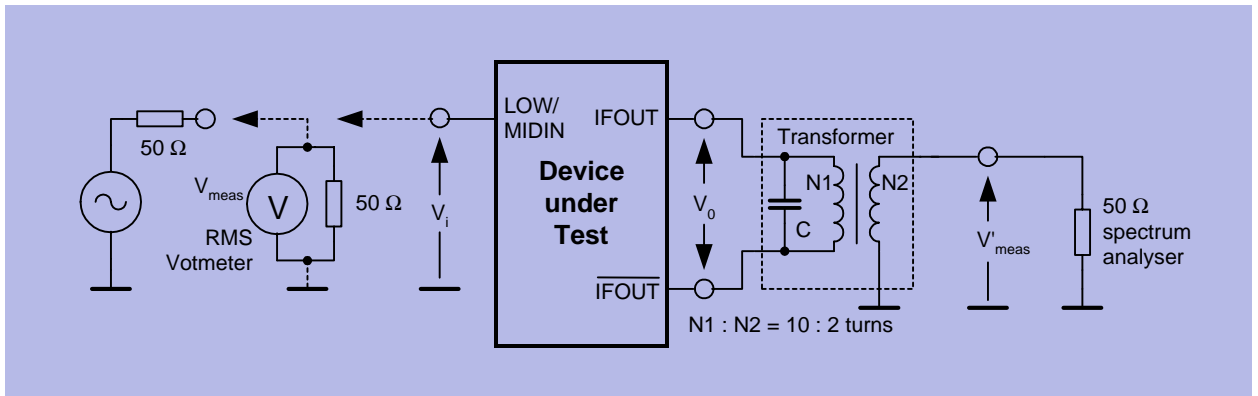

GVHF2

- $Z_i \gg 50 \Omega \Rightarrow V_i = 2 \times V_{meas} = 80 \text{ dB}\mu\text{V}$
- $V_i = V_{meas} + 6\text{dB} = 80 \text{ dB}\mu\text{V}$
- $V_0 = V'_{meas} + 16 \text{ dB}$ (transformer ratio N1:N2 and transformer loss)
- $G_v = 20 \log(V_0 / V_i)$

5.4.2 Gain (G_V) test Set-up in HIGH

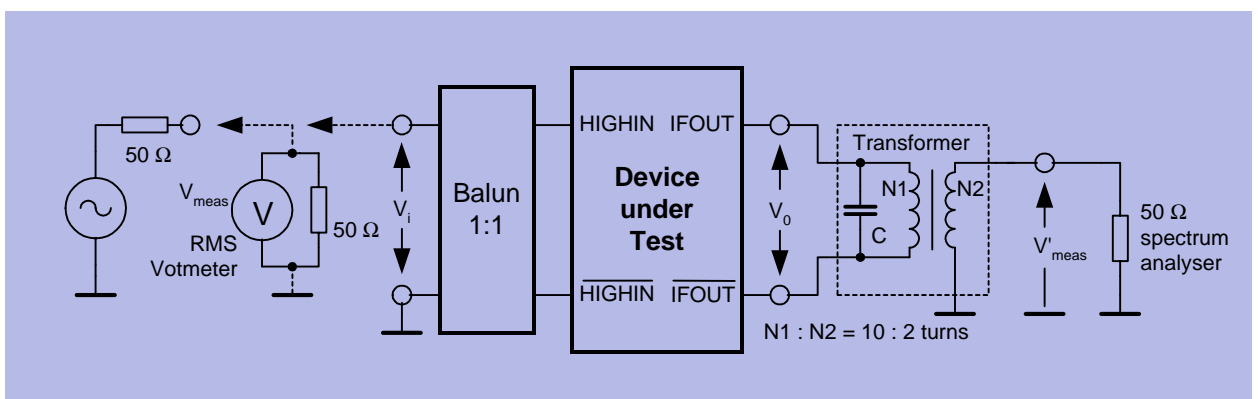

GVHF2

- $V_i = V_{meas} = 70 \text{ dB}\mu\text{V}$
- $V_0 = V'_{meas} + 16 \text{ dB}$ (transformer ratio N1:N2 and transformer loss)
- $G_v = 20 \log(V_0 / V_i) + 1 \text{ dB}$ (1 dB = insertion loss of balun)

5.4.3 Matching circuit for optimum noise figure in LOW/MID

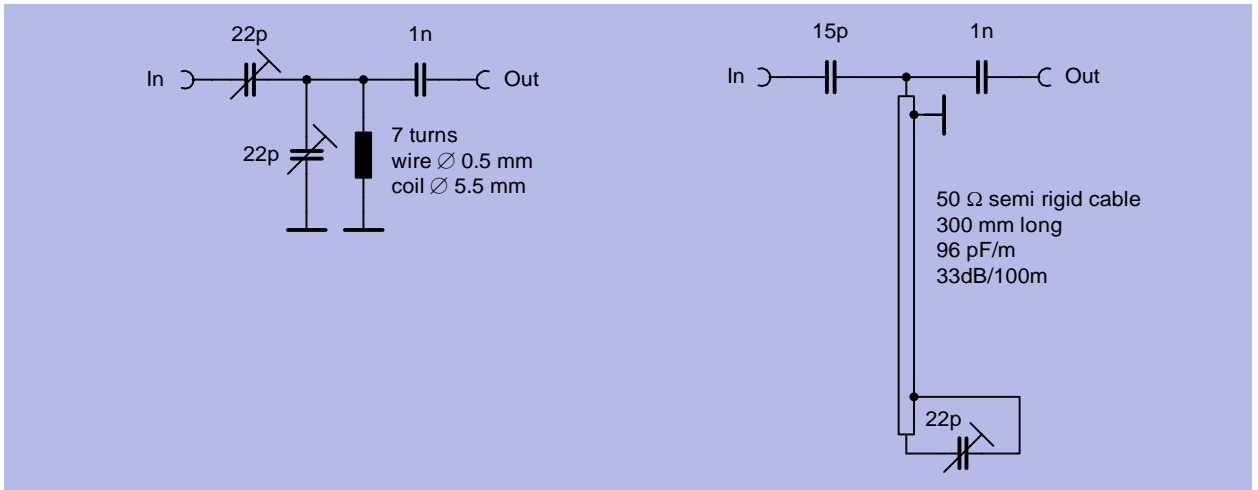

NFM

For $f_{RF} = 50 \text{ MHz}$

- loss = 0 dB
- image suppression = 16 dB

For $f_{RF} = 150 \text{ MHz}$

- loss = 1.3 dB
- image suppression = 13 dB

5.4.4 Noise Figure Test Set-up in LOW/MID

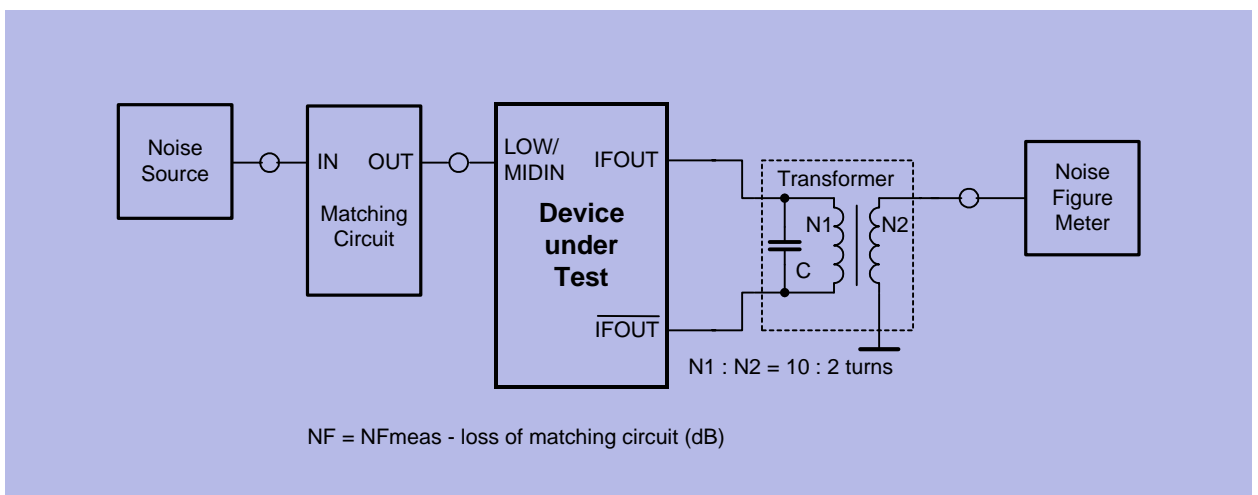

$$NF = NF_{meas} - \text{loss of matching circuit (dB)}$$

NFVHF2

5.4.5 Noise Figure Test Set-up in HIGH

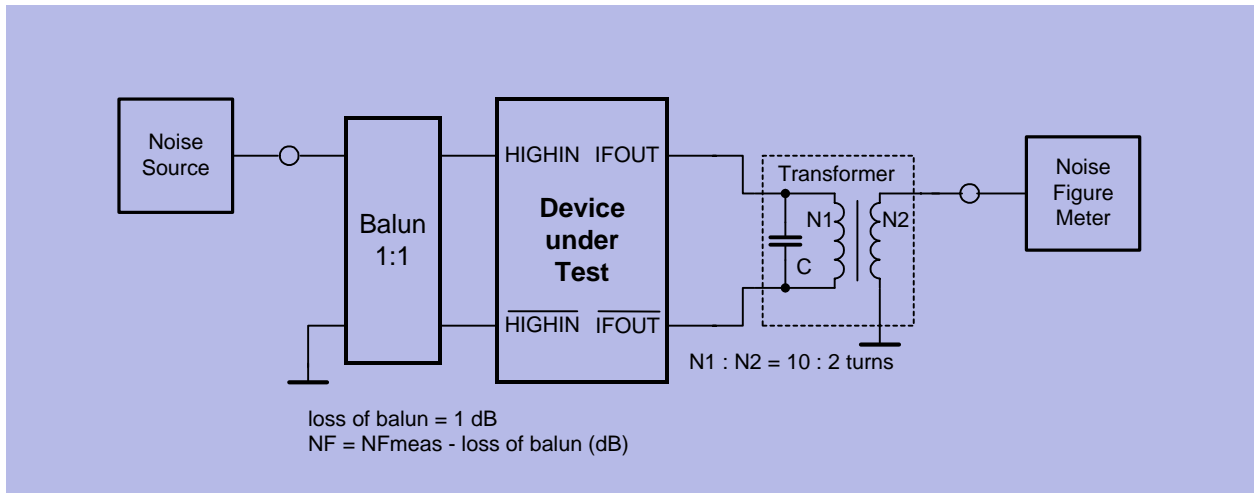

NFUHF2

5.4.6 Measurement of f_{ref} and f_{div}

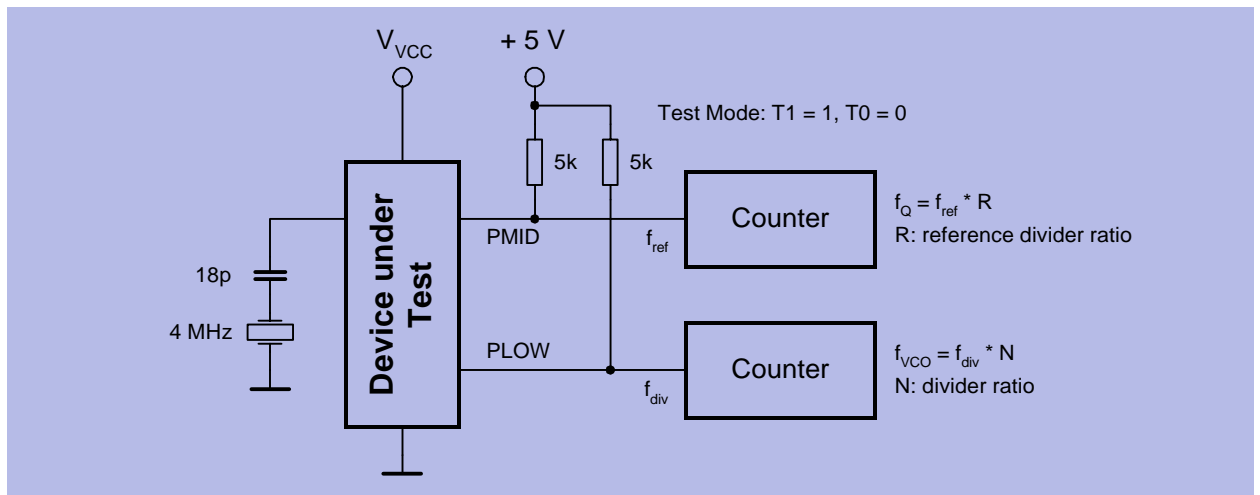

freq_meas_cof